

VALVES SERIES 70

The Series 70 forms part of Metal Work's full range of traditional valves.

They are available in sizes 1/8", 1/4", 3/8" and 1/2", versions 3/2, 5/2, 5/3 and double 3/2, with mechanical, manual, pneumatic and electric drives.

They can be installed in line, onto a wall, on the cylinder (using a special bracket) or in series (on a multiple or modular base) to suit all possible applications.

A range of valves (Series 70 LT) designed using components for specific low-temperature applications is now available for the most commonly used types and sizes.

These highly reliable valves comply with the main applicable standards, including ATEX, ISO 13489 and SIL, as stated in the documents and certificates available online.



TECHNICAL DATA		1/8"	1/4"	3/8"	1/2"
Thread on the valve ports		1/8"	1/4"	3/8"	1/2"
Operating pressure series 70 versions	bar			2.5 to 10	
monostable and bistable differential				1 to 10	
bistable				vacuum to 10	
asserved					
Operating pressure series 70 LT (low temperature) versions	bar				
hand operated	perfectly	vacuum to 10			-
pneumatic and solenoid/pneumatic	t = -40°C to -10°C	5 to 10			-
	t = -10°C to +60°C	3 to 10			-
Minimum pilot pressure	bar			2.5	
Operating temperature range	°C				
series 70 versions				-10 to +60	
series 70 LT (low temperature) versions				-40 to +60	
Nominal diameter	mm	5	7.5	13.3	15
Conductance C	Nl/min · bar	121.43	264.26	505.52	971.43
Critical ratio b	bar/bar	0.32	0.27	0.32	0.43
Flow rate at 6 bar ΔP 0.5 bar	Nl/min	400	750	1560	3200
Flow rate at 6 bar ΔP 1 bar	Nl/min	550	1100	2150	4600
Installation		In any position (vertical assembly is not recommended for bistable valves subjected to vibration)			
Fluid		Filtered air without lubrication; lubrication, if used, must be continuous.			
Recommended lubricant		For series 70 LT (low-temperature) versions, it is recommended to use of perfettamente dried air. ISO and UNI FD 22			
Maximum coil nut torque	Nm	For series 70 LT (low-temperature) it is not expected to be used with lubricated air.			
Compatibility with oils		1 See chapter Z1			

COMPONENTS SERIES 70

- ① ALVE BODY: Aluminium
- ② CONTROL/END CAP: plastic
- ③ SPOOL: chemically nickel-plated aluminium
- ④ DISTANCE PLATES: plastic
- ⑤ GASKETS: NBR
- ⑥ PISTONS: Hostaform®
- ⑦ PISTON GASKET: NBR
- ⑧ FILTER: plastic
- ⑨ SPRINGS: special steel
- ⑩ OPERATOR: Brass pipe - Stainless steel core

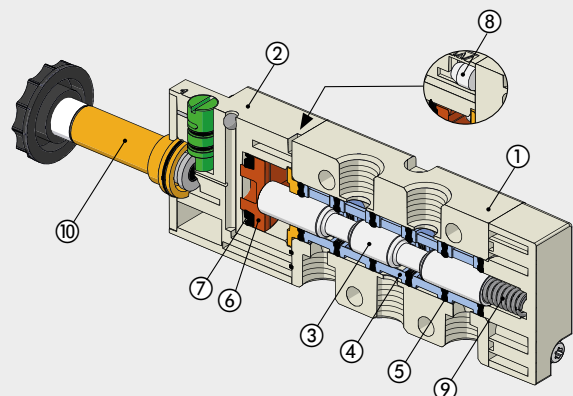

COMPONENTS SERIES 70 LT (LOW TEMPERATURE)

- ① ALVE BODY: aluminium
- ② CONTROL/END CAP: aluminium
- ③ SPOOL: chemically nickel-plated aluminium
- ④ DISTANCE PLATES: plastic
- ⑤ GASKETS: HNBR
- ⑥ PISTONS: aluminium
- ⑦ PISTON GASKET: HNBR
- ⑧ FILTER: plastic
- ⑨ SPRINGS: special steel
- ⑩ OPERATOR: brass pipe - Stainless steel core (version specific for low-temperature applications)

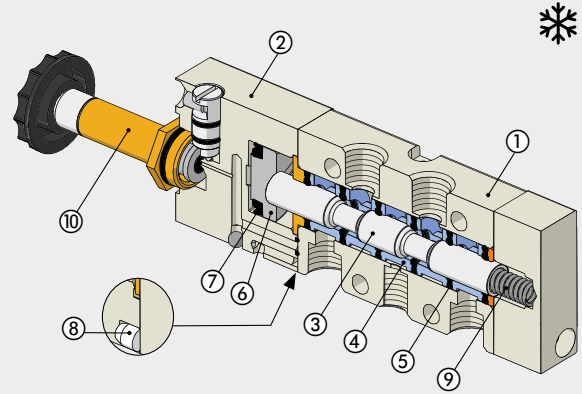

FLOW CHARTS

VALVES SERIES 70 1/8"

Flow rates

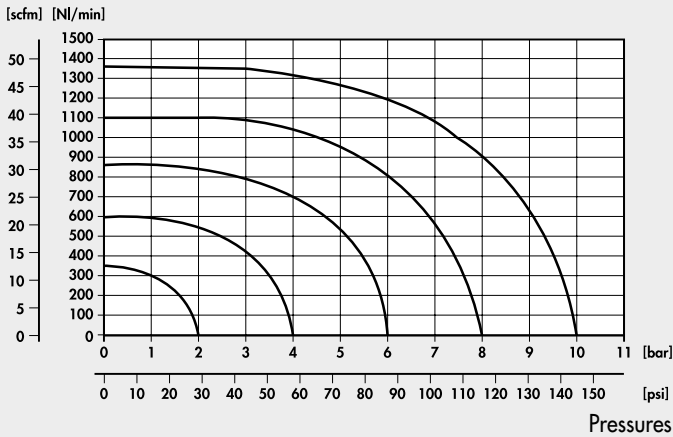

VALVES SERIES 70 1/4"

Flow rates

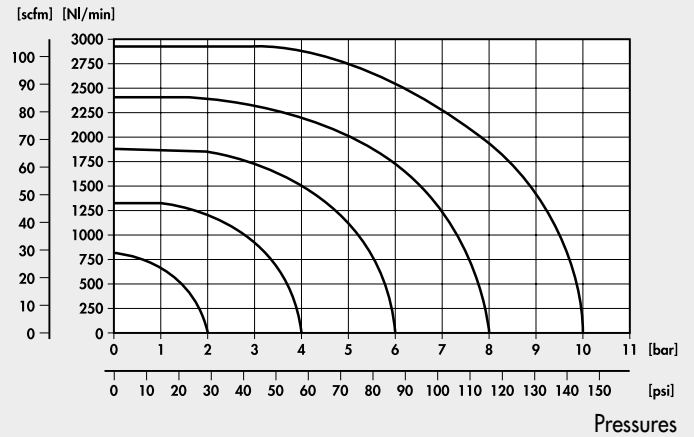

VALVES SERIES 70 3/8"

Flow rates

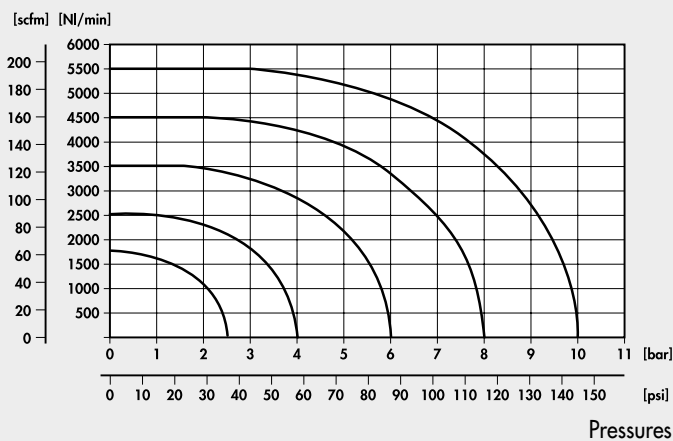

VALVES SERIES 70 1/2"

Flow rates

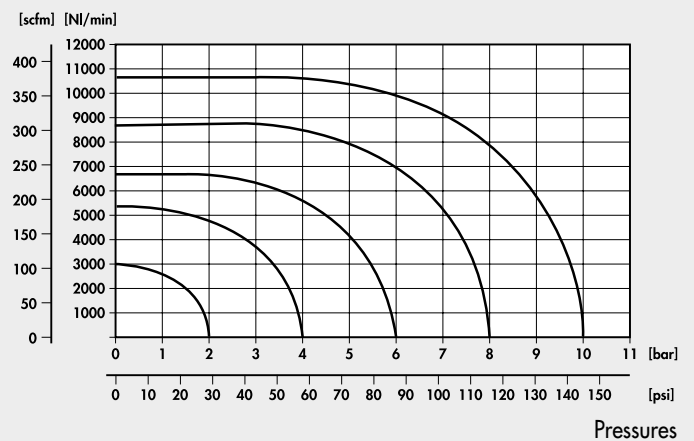

VALVES SERIES 70

VALVES SERIES 70 LT (LOW TEMPERATURE)

TECHNICAL DATA		1/8"	1/4"
Operating pressure standard	bar	Vacuum to 10	
hand operated		5 to 10	
pneumatic and solenoid/pneumatic	t = -40°C to -10°C	3 to 10	
	t = -10°C to +60°C	-40 to +60	
Operating temperature range	°C		
Nominal diameter	mm	5	7.5
Conductance C	Nl/min · bar	121.43	264.26
Critical ratio b	bar/bar	0.32	0.27
Flow rate at 6 bar ΔP 0.5 bar	Nl/min	400	750
Flow rate at 6 bar ΔP 1 bar	Nl/min	550	1100
PNEUMATIC			
Minimum pilot pressure	bar	5	
t = -40°C to -10°C		3	
t = -10°C to +60°C			
TRA / TRR monostable at 6 bar (at 20°C)	ms	6/15	7/15
TRA / TRR bistable at 6 bar (at 20°C)	ms	7/7	7/7
SOLENOID/PNEUMATIC			
TRA / TRR monostable at 6 bar (at 20°C)	ms	15/35	19/45
TRA / TRR bistable at 6 bar (at 20°C)	ms	20/20	21/21
Coil voltage values		12; 24 VDC	
		24; 110; 220V AC 50/60Hz	
Power t = -40°C to -10°C		5 W (DC) - 5 VA (AC)	
	t = -10°C to +60°C	2 W (DC) - 3.5 VA (AC)	
Voltage tolerance	%	-10 to +15	
Insulation class		F 155	
Maximum coil nut torque	Nm	1	
Hand operation		Bistable	
Notes: after a long stop and with very low temperatures the movement of the first drives may be slower. It recommends the use of perfectly dry air.			



VALVES

VALVES SERIES 70 LT (LOW TEMPERATURE)

SYNOPTIC, SIZES AND VERSIONS

PNV FAMILY		2 DIMENSIONS	3 FUNCTION	PN OPERATORS 14	S RESETTING (12)	OO FURTHER DETAILS	LT
MAV	valvole manuali	2 1/8"	3 3/2	LE leva 90°	S mechanical springs	OO no indication	LT low temperature
PNV	pneumatic valves	3 1/4"	5 5/2	PN pneumatic	B bistable	NC normally closed	
SOV	solenoid/ pneumatic		6 5/3	SO solenoid	O stable for 5/3	NO normally open	
						CC closed centres	
						OC open centres	
						PC pressure centres	

VALVES SERIES 70 LT, HAND OPERATED (LOW TEMPERATURE)

90° LEVER 3/2 1/8"

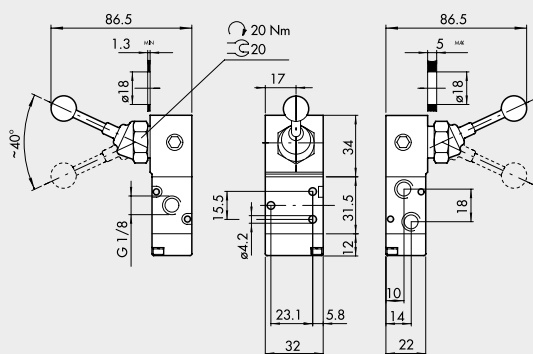

90° LEVER 5/2 1/8"

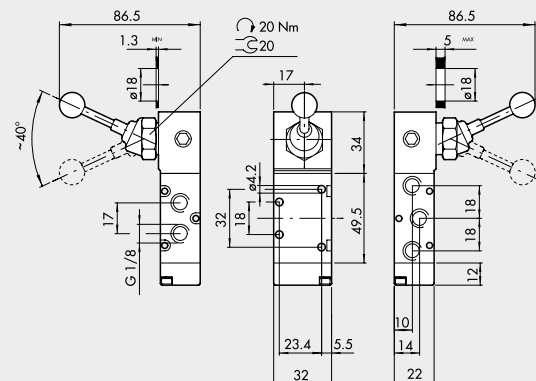

Symbol	Code	Abbrev.	Weight [g]
	* 70L1000100	MAV 23 LES NC LT	184
	* 70L1000200	MAV 23 LEB OO LT	187

Symbol	Code	Abbrev.	Weight [g]
	* 70L1000300	MAV 25 LES OO LT	210
	* 70L1000400	MAV 25 LEB OO LT	213

90° LEVER 5/3, 1/8"

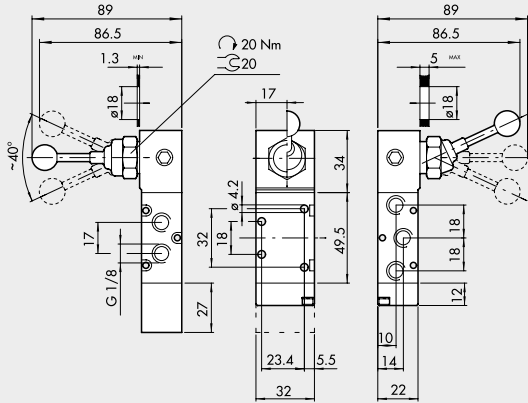

Symbol	Code	Abbrev.	Weight [g]
	70L1001000	MAV 26 LES CC LT	242
	70L1000900	MAV 26 LES OC LT	242
	70L1001100	MAV 26 LES PC LT	242
	70L1000500	MAV 26 LEO CC LT	194
	70L1000600	MAV 26 LEO OC LT	194
	70L1000700	MAV 26 LEO PC LT	194

90° LEVER 3/2, 1/4"

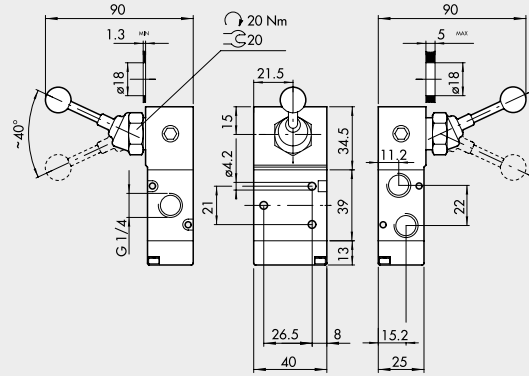

Symbol	Code	Abbrev.	Weight [g]
	70L2000100	MAV 33 LES NC LT	272
	70L2000200	MAV 33 LEB OO LT	272

90° LEVER 5/2, 1/4"

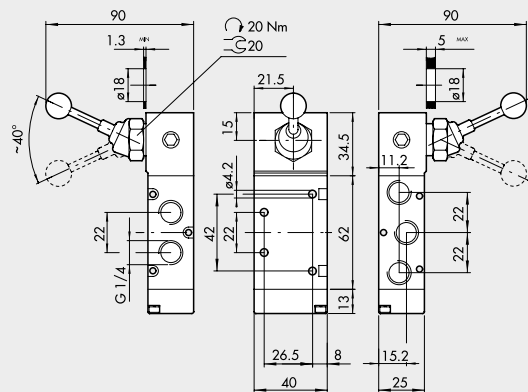

Symbol	Code	Abbrev.	Weight [g]
	70L2000300	MAV 35 LES OO LT	326
	70L2000400	MAV 35 LEB OO LT	326

90° LEVER 5/3, 1/4"

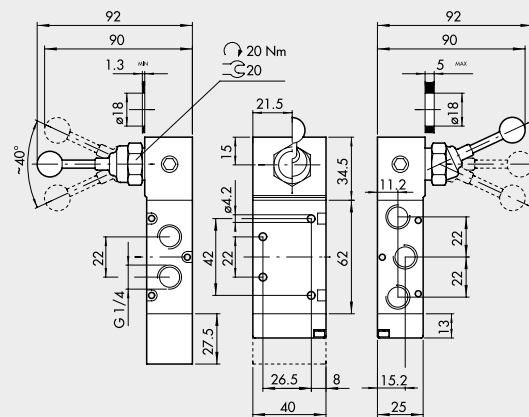

Symbol	Code	Abbrev.	Weight [g]
	70L2001000	MAV 36 LES CC LT	354
	70L2000900	MAV 36 LES OC LT	354
	70L2001100	MAV 36 LES PC LT	354
	70L2000500	MAV 36 LEO CC LT	288
	70L2000600	MAV 36 LEO OC LT	288
	70L2000700	MAV 36 LEO PC LT	288

VALVES SERIES 70 LT, PNEUMATIC (LOW TEMPERATURE)

BISTABLE 5/2, 1/8"

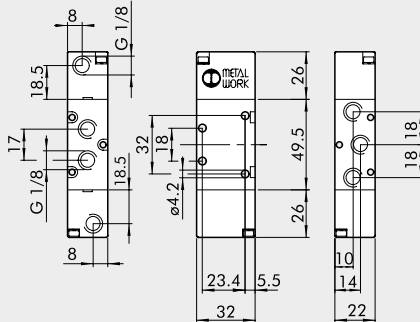

Symbol	Code	Abbrev.	Weight [g]
	* 70L1011200	PNV 25 PNB OO LT	176

BISTABLE 3/2, 1/8"

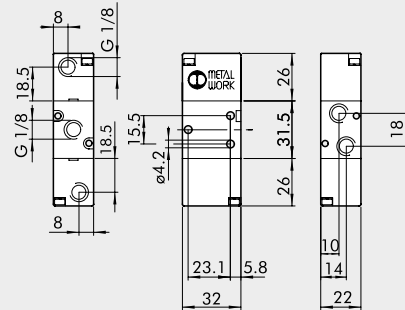

Symbol	Code	Abbrev.	Weight [g]
	* 70L1010100	PNV 23 PNB OO LT	150

BISTABLE 5/2, 1/4"

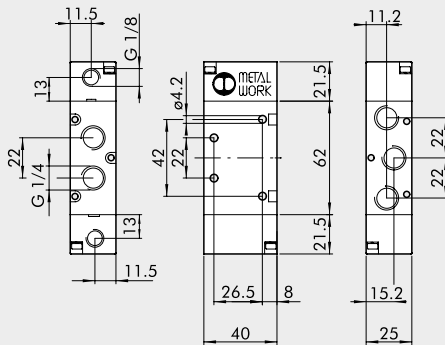

Symbol	Code	Abbrev.	Weight [g]
	* 70L2011200	PNV 35 PNB OO LT	233

BISTABLE 3/2, 1/4"

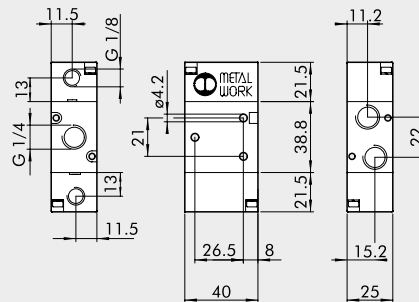

Symbol	Code	Abbrev.	Weight [g]
	* 70L2010100	PNV 33 PNB OO LT	194

VALVES SERIES 70 LT, SOLENOID/PNEUMATIC (LOW TEMPERATURE)

MONOSTABLE 3/2 NO, 1/8"

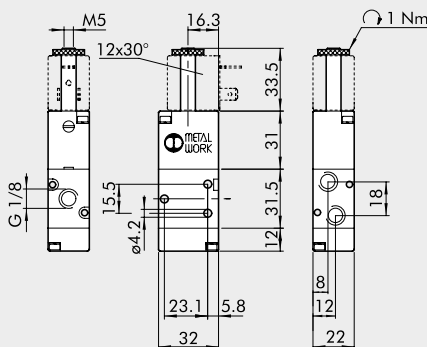

Symbol	Code	Abbrev.	Weight [g]
	* 70L1020400	SOV 23 SOS NO LT	147

MONOSTABLE 3/2 NC, 1/8"

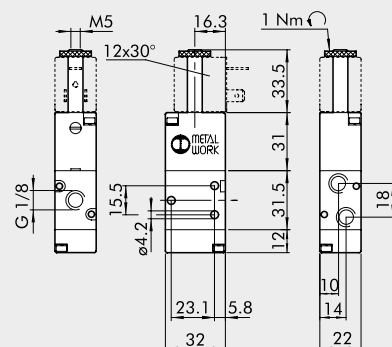

Symbol	Code	Abbrev.	Weight [g]
	* 70L1020200	SOV 23 SOS NC LT	147

MONOSTABLE 5/2, 1/8"

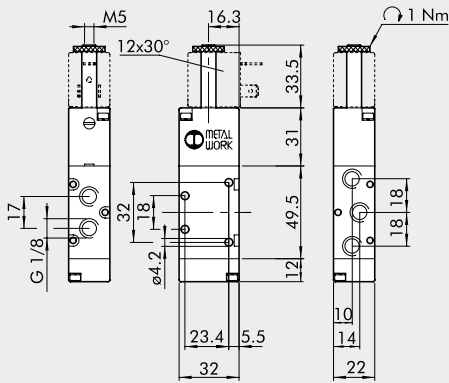

Symbol	Code	Abbrev.	Weight [g]
	* 70L1021100	SOV 25 SOS OO LT	175

BISTABLE 5/2, 1/8"

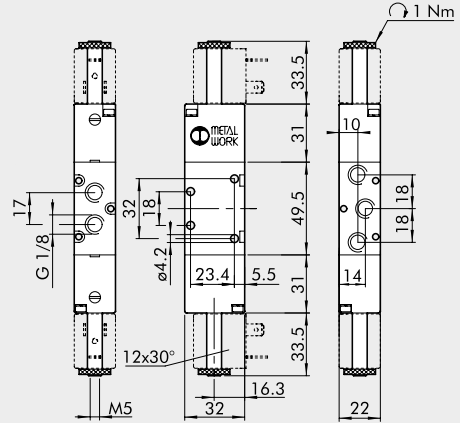

Symbol	Code	Abbrev.	Weight [g]
	* 70L1021200	SOV 25 SOB OO LT	228

BISTABLE 3/2, 1/8"

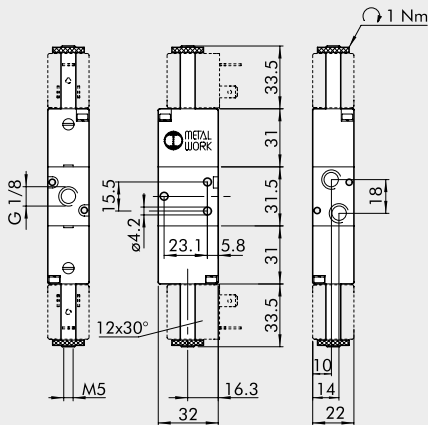

Symbol	Code	Abbrev.	Weight [g]
	* 70L1020100	SOV 23 SOB OO LT	203

MONOSTABLE 3/2 NO, 1/4"

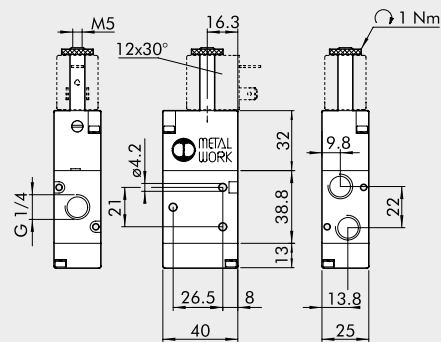

Symbol	Code	Abbrev.	Weight [g]
	* 70L2020400	SOV 33 SOS NO LT	230

MONOSTABLE 3/2 NC, 1/4"

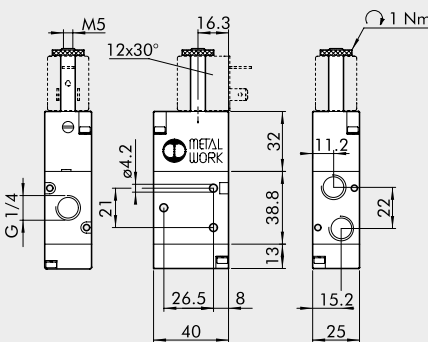

Symbol	Code	Abbrev.	Weight [g]
	* 70L2020200	SOV 33 SOS NC LT	230

MONOSTABLE 5/2, 1/4"

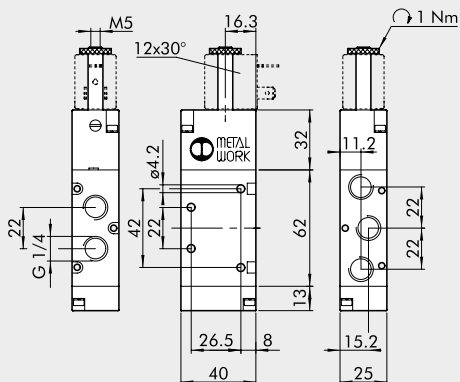

Symbol	Code	Abbrev.	Weight [g]
	* 70L2021100	SOV 35 SOS OO LT	278

BISTABLE 5/2, 1/4"

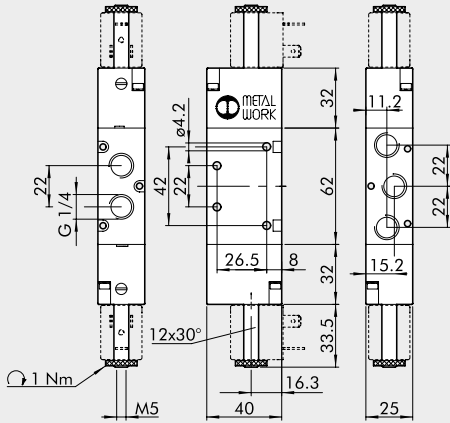

Symbol	Code	Abbrev.	Weight [g]
*	70L2021200	SOV 35 SOB OO LT	332

BISTABLE 3/2, 1/4"

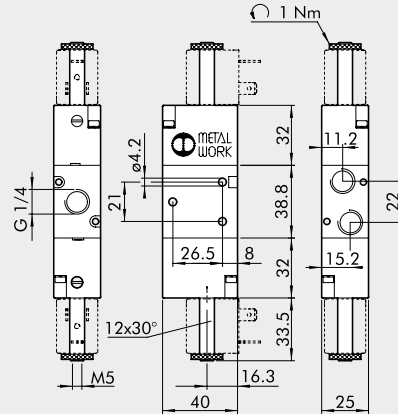

Symbol	Code	Abbrev.	Weight [g]
*	70L2020100	SOV 33 SOB OO LT	286

COILS AND CONNECTORS



Refer to page B1.60 for coils and connectors
 For temperatures $T < -10\text{ }^{\circ}\text{C}$ it is necessary to use coils side 22 mm from 5 W or 5 VA .
 (see page B1.77)

NOTES