

# IN-LINE PRESSURE GAUGE SERIES MAN L

The MAN L pressure gauge belongs to the LINE ON LINE® family, which means it can be connected to all the other components in series or in parallel.

Available in the version for pipe-pipe connection with two push-in fittings, and in the version for thread-pipe connection with a brass nickel-plated male thread and a push-in fitting.

Though small in size, this pressure gauge, which is supplied in a metal casing, ensures accurate reading. It can be angled in any direction simply by rotating manually.



## TECHNICAL DATA

		Ø 4 (Ø5/32")	Ø 6	Ø 1/4"	Ø 8 (Ø5/16")
Operating pressure	MPa			1.2	
	bar			12	
	psi			174	
Temperature range	°C			- 20 to + 60	
	°F			- 4 to + 140	
Precision				± 4% full scale	
Recommended pipe		Rilsan PA11 - Nylon 6 - Polyamide 12 - Polypropylene			
Fluid		Lubricated or unlubricated filtered compressed air; if used, must be continuous			
Compatibility with oils		See chapter Z1			

## ASSEMBLY OPTIONS

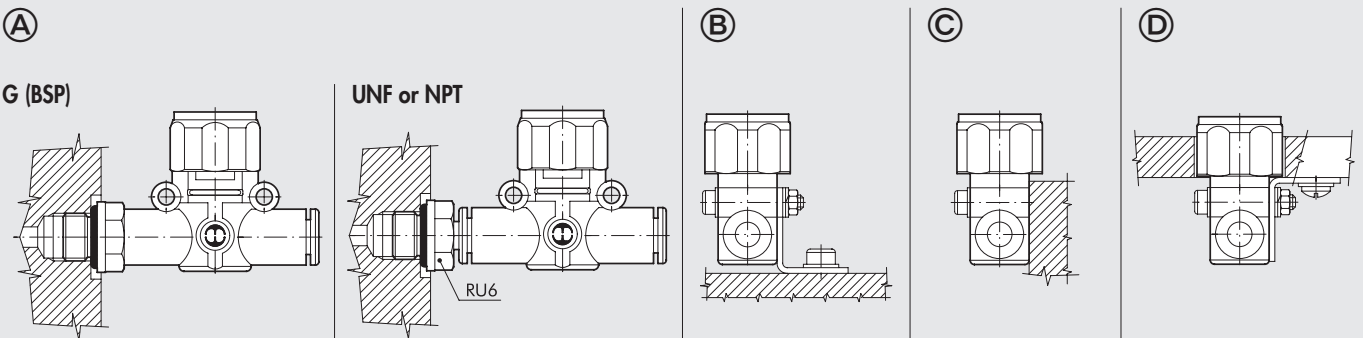

How to mount the MAN L:

- Fig. **A** **G (BSP)**: With the male threaded port it is possible to mount the MAN L straight onto the female thread.  
**UNF or NPT**: Adding a RU6 fitting, with his male UNF or NPT thread, it is possible to mount the MAL L straight on to the actuator or the control valve.
- Fig. **B** Fixing to the plate with the special SQU L bracket.
- Fig. **C** There are two robust rings on the plastic body for fixing the MAN L straight onto the wall.
- Fig. **D** Use the SQL L bracket for panel mounting the MAN L.

## MAN L PIPE - PIPE

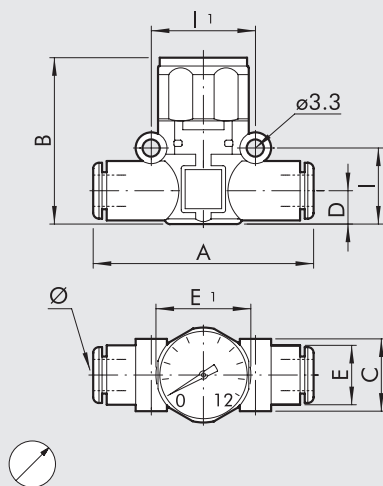

Code	Ref.	Ø	A	B	C	D	E	E1	I	I1
9067001	MAN L Ø4-Ø4	4 ▲	41.8	36.1	10.7	5.6	10	23	12.8	16
9067016	MAN L Ø6-Ø6	6	49.4	35	14.7	6.4	11.4	23	14.6	20
9067016U	MAN L Ø1/4-Ø1/4	1/4	49.4	35	14.7	6.4	11.4	23	14.6	20
9067024	MAN L Ø8-Ø8	8 ▲	57.3	41	18.7	9.1	13.8	23	18.7	24

▲ Ø4 = Ø5/32"; Ø8 = Ø5/16"

## MAN L G (BSP) THREAD - PIPE

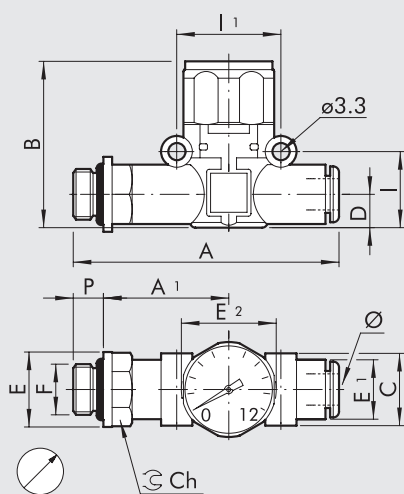

Code	Ref.	F	Ø	P	A	A1	B	C	D	E	E1	E2	I	I1	Ch
9067101	MAN L M5-Ø4	M5	4 ▲	4	47.7	22.7	36.1	10.7	5.6	9.9	10	23	12.8	16	9
9067102	MAN L 1/8-Ø4	1/8	4 ▲	6	51.5	24.6	36.1	10.7	5.6	14	10	23	12.8	16	12
9067108	MAN L 1/8-Ø6	1/8	6	6	58.5	27.8	35	14.7	6.4	14	11.4	23	14.6	20	12
9067109	MAN L 1/4-Ø6	1/4	6	8	61.5	28.8	35	14.7	6.4	18	11.4	23	14.6	20	14
9067110	MAN L 1/8-Ø8	1/8	8 ▲	6	66.2	31.8	41	18.7	9.1	15	13.8	23	18.7	24	14
9067111	MAN L 1/4-Ø8	1/4	8 ▲	8	70.6	34.2	41	18.7	9.1	18	13.8	23	18.7	24	14
9067112	MAN L 3/8-Ø8	3/8	8 ▲	9	72.2	34.8	41	18.7	9.1	22	13.8	23	18.7	24	17

▲ Ø4 = Ø5/32"; Ø8 = Ø5/16"

## NOTES